

Revisions

Issue	Date	Note
3	24/05/2018	See note 268529806

ASSEMBLY VIEW

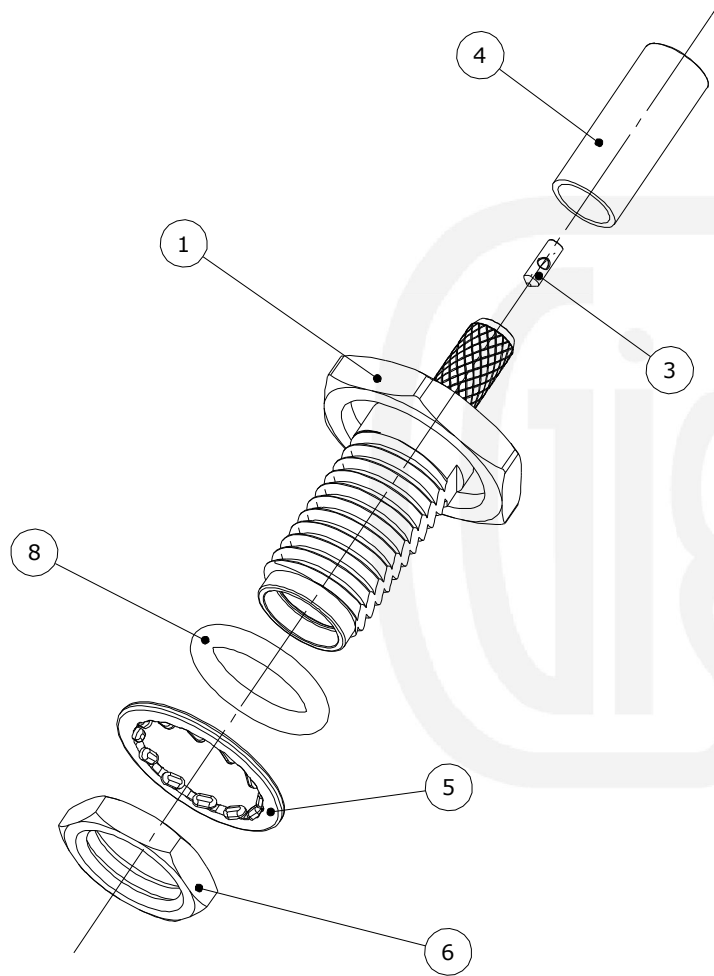

Assembly Instructions:

1) Slide the ferrule onto the cable and strip the cable to the dimensions as shown, taking care not to nick the centre conductor or braid



2) Solder the pin onto the centre core and slide the pin into the body, ensuring that the cable braid is on the outside of the connector mandril and that the pin is fully located

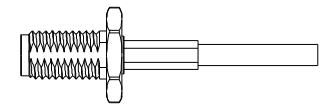

3) Slide the ferrule forward and crimp

Crimp Hex. Sizes:

3.25mm Hex, Solder centre core

Strip Dimensions:

A=6.0mm, B=4.0mm, C=1.5mm

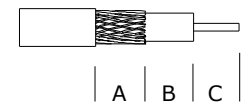

8	O Ring	Silicone	Black
7	Dielectric	PTFE	White
6	Lock Nut	Brass	Gold
5	Washer	Phosphor Bronze	Gold
4	Ferrule	Brass	Gold
3	Pin	Brass	Gold
2	Contact	Berllium Copper	Gold
1	Body	Brass	Gold
	Description	Material	Finish

Unless otherwise specified tolerances
 0.5-5 = ±0.2
 >5-30 = ±0.4
 >30-120 = ±0.6
 >120-315 = ±1.0
 >315-1000 = ±1.6
 Angles = ±5°
 Units = mm

This document is the confidential property of Gigatronix Limited and may not be copied, reproduced or transmitted to any third party without written authorisation.



Author	PJP
Drawn by	PJP
Drawing date	13/05/2015
Checked by	DB
Checked date	24/05/2018
Scale	Not to scale

Part Number MA02-3161-C01WP
Title: SMA Waterproof Crimp Bulkhead Jack, IP68, Gold Plated, RG174, LBC100, RG316