

Revisions

Issue	Date	Note
2	12/12/2018	See note 525475906

ASSEMBLY VIEW

Assembly Instructions:

1) Slide the ferrule onto the cable and strip the cable to the dimensions as shown, taking care not to nick the centre conductor or braid



2) Solder the pin onto the centre core and then slide it into the hole in the small insulator. Then push into the body, ensuring that the cable braid is on the outside of the connector mandril and that the centre pin is located within the integral pin

3) Slide the ferrule forward and crimp.

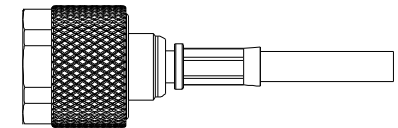

4) Apply adhesive lined heatshrink x 25mm up and over the mandril

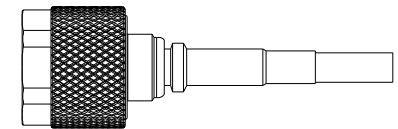

5) Apply adhesive lined heatshrink x 30mm over the top of the first heatshrink

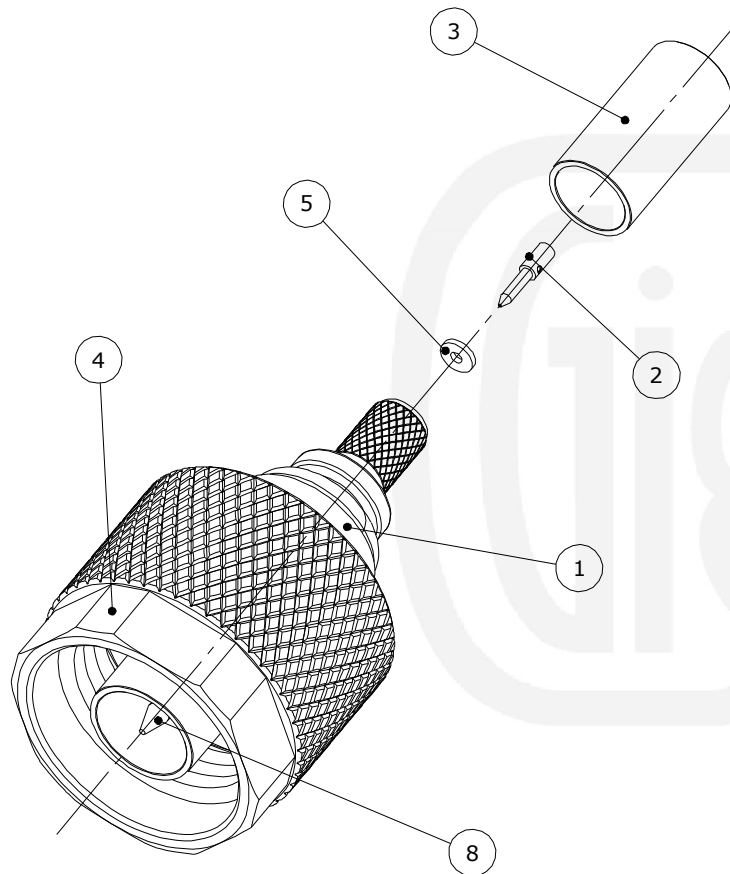
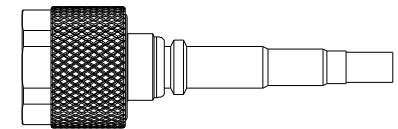

Strip Dimensions:

A=7.5mm, B=1.9mm, C=1.5mm

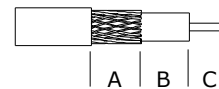

Crimp Hex. Sizes:

5.41mm Hex., Solder centre core

8	Integral Pin	Phosphor Bronze	Gold
7	Dielectric	PTFE	White
6	Grommet	Silicone	Orange
5	Insulator	PTFE	White
4	Coupling Nut	Brass	Tri-Alloy
3	Ferrule	Brass	Tri-Alloy
2	Pin	Brass	Gold
1	Body	Brass	Tri-Alloy
	Description	Material	Finish

Unless otherwise specified tolerances
 0.5-5 = ±0.2
 >5-30 = ±0.4
 >30-120 = ±0.6
 >120-315 = ±1.0
 >315-1000 = ±1.6
 Angles = ±5°
 Units = mm

This document is the confidential property of Gigatronix Limited and may not be copied, reproduced or transmitted to any third party without written authorisation.



Author	PJP
Drawn by	PJP
Drawing date	01/04/14
Checked by	DB
Checked date	14/12/2018
Scale	Not to scale

Part Number NT15-0058-C49WP

Title: N Type Waterproof Crimp Plug, IP68, Tri-Alloy Plated, Hex Coupling Nut, RG58, LBC195, URM43